

FIG. 1 (prior art)

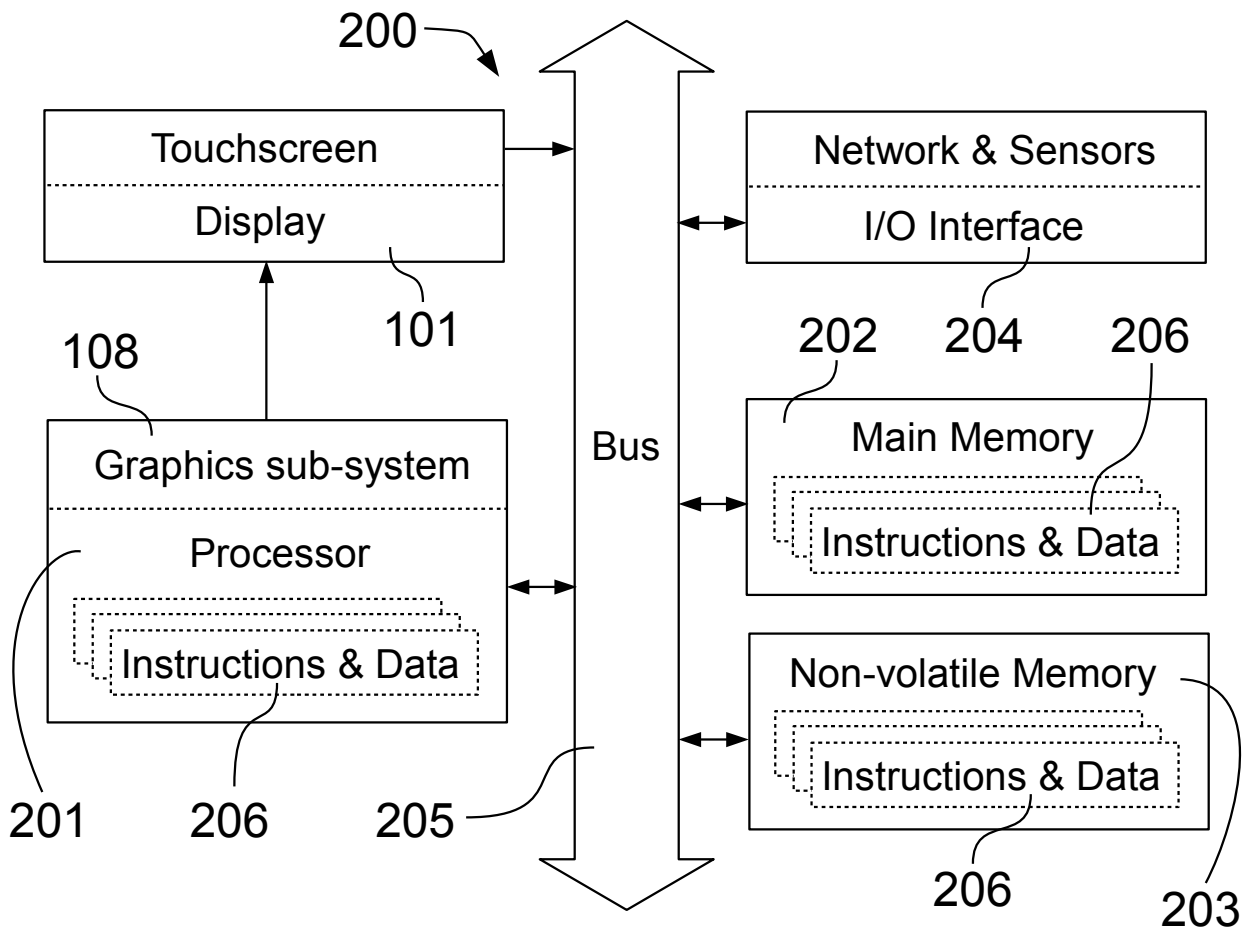

FIG. 2 (prior art)

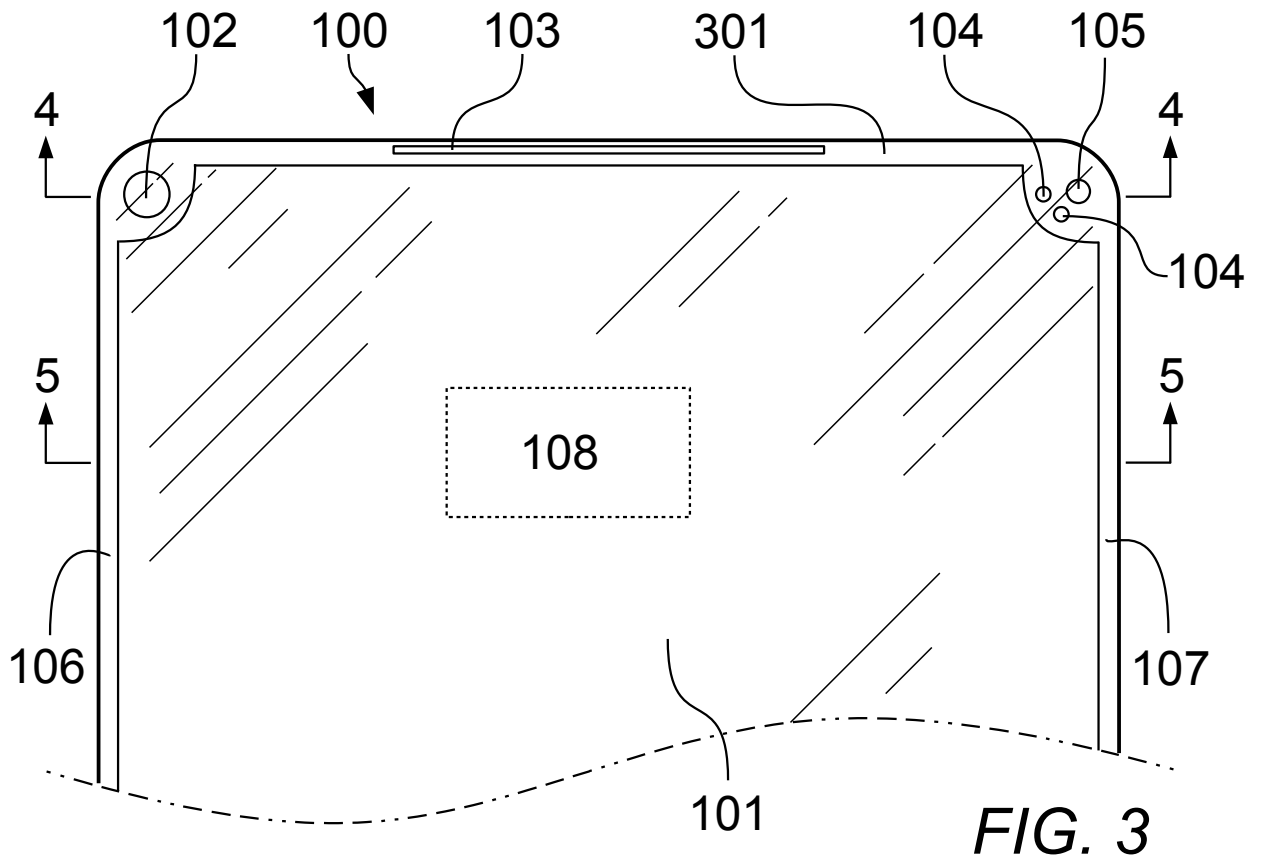

FIG. 3

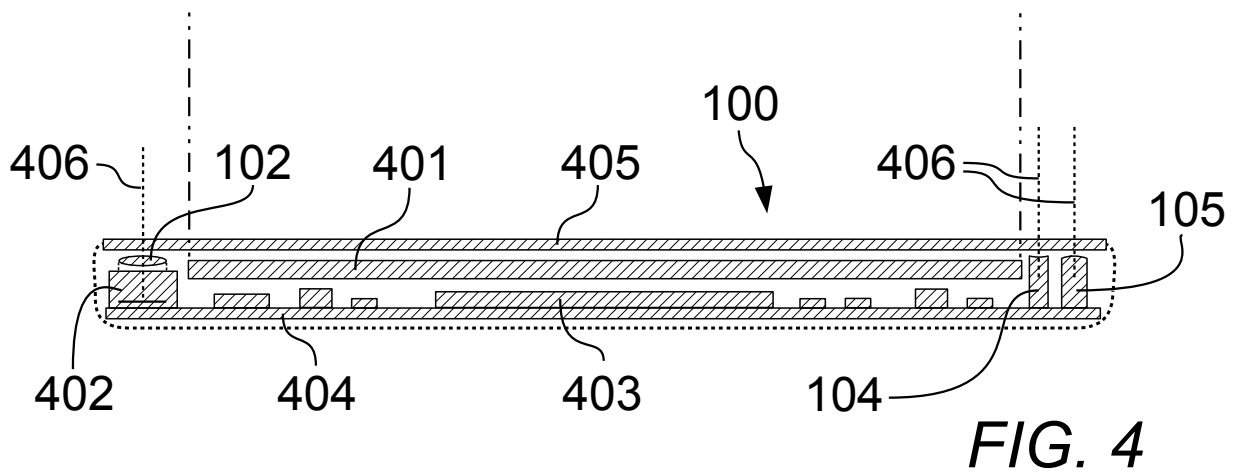

FIG. 4

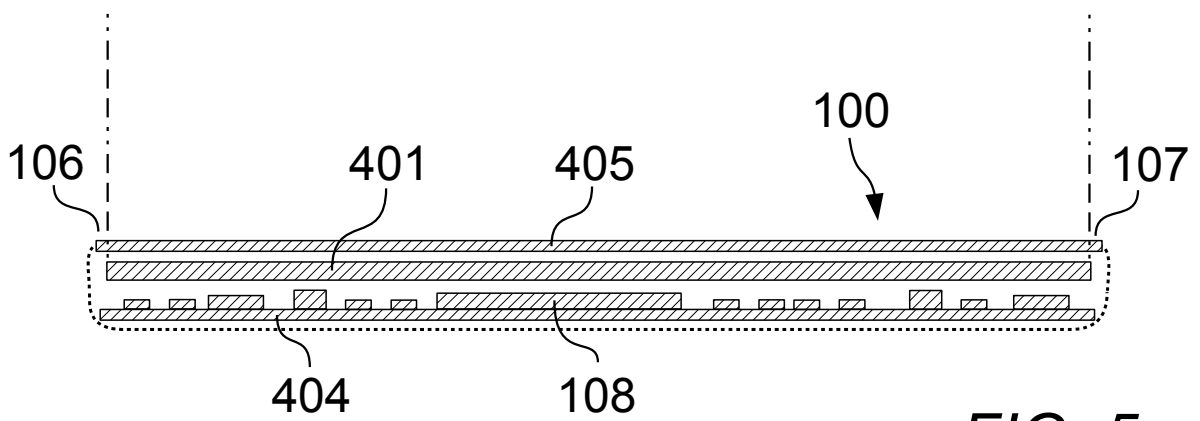

FIG. 5

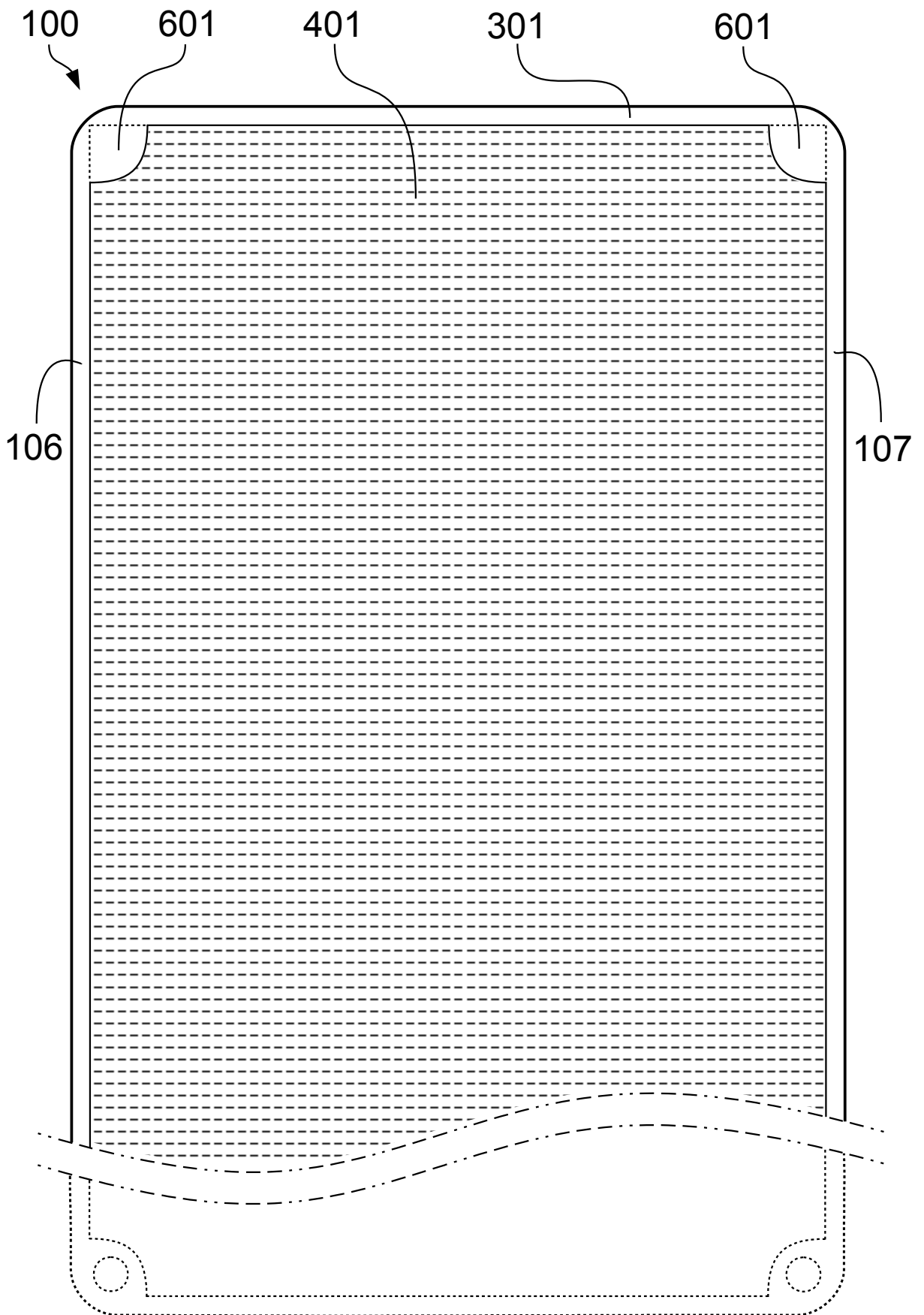

FIG. 6

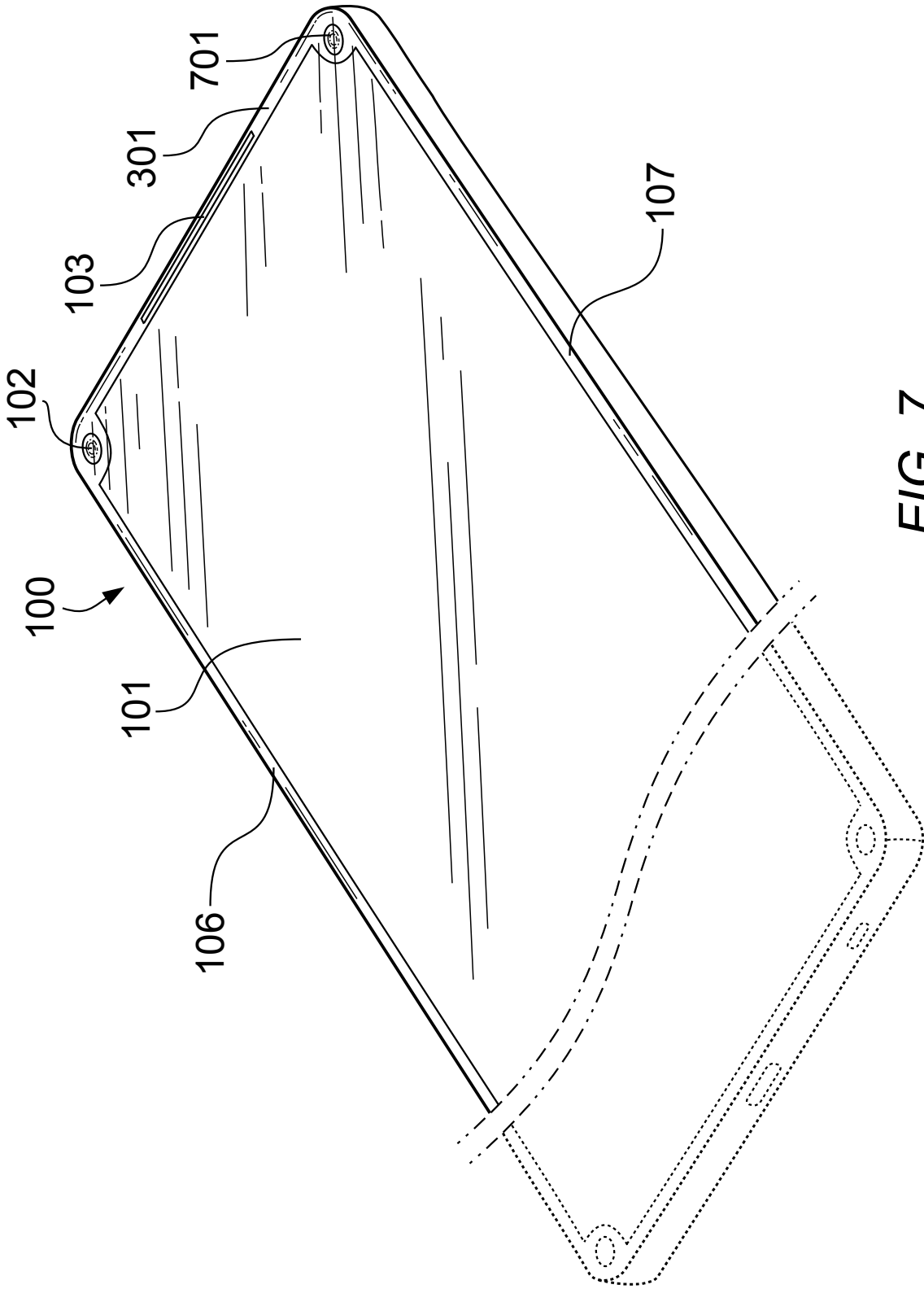

FIG. 7

5/25

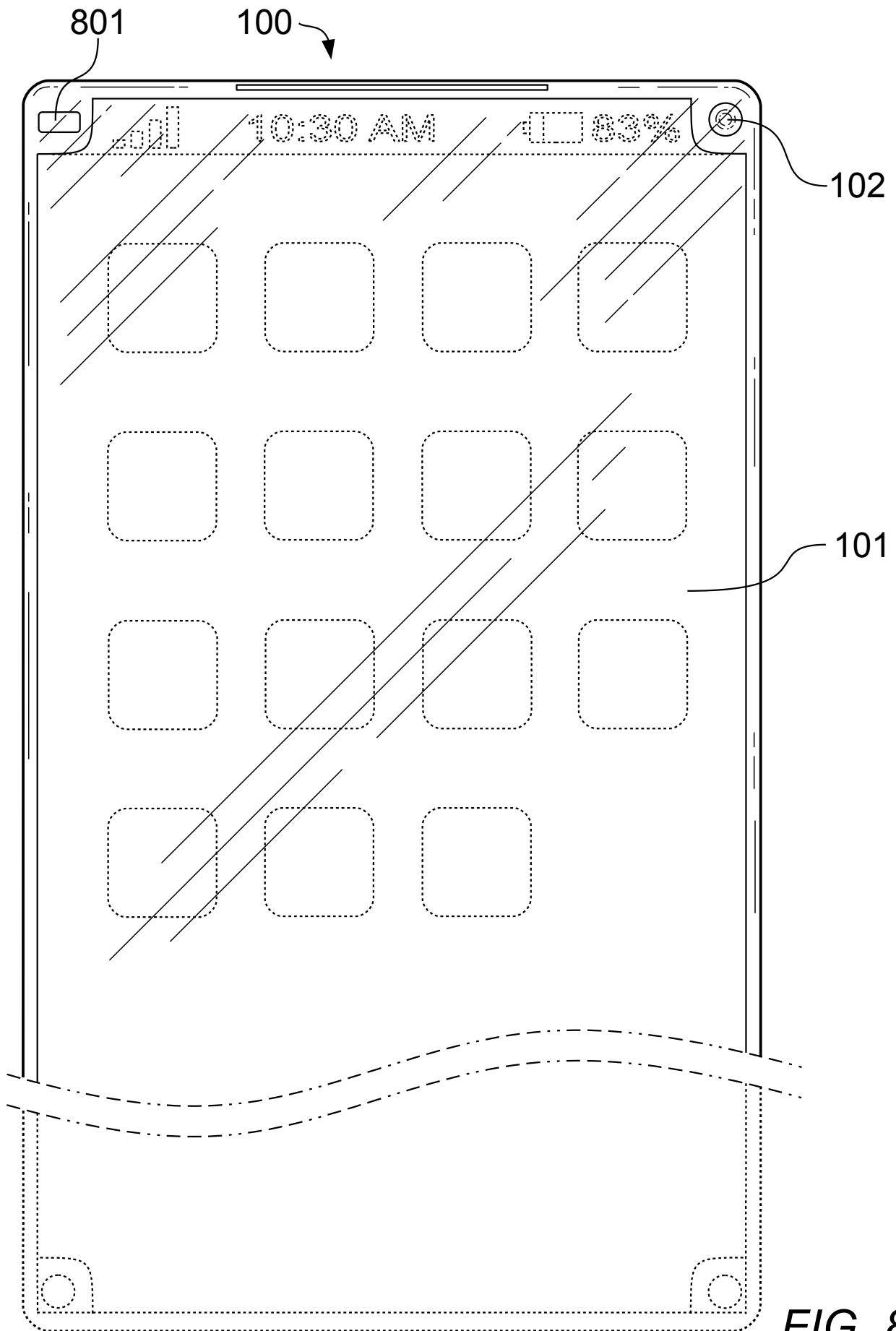

FIG. 8

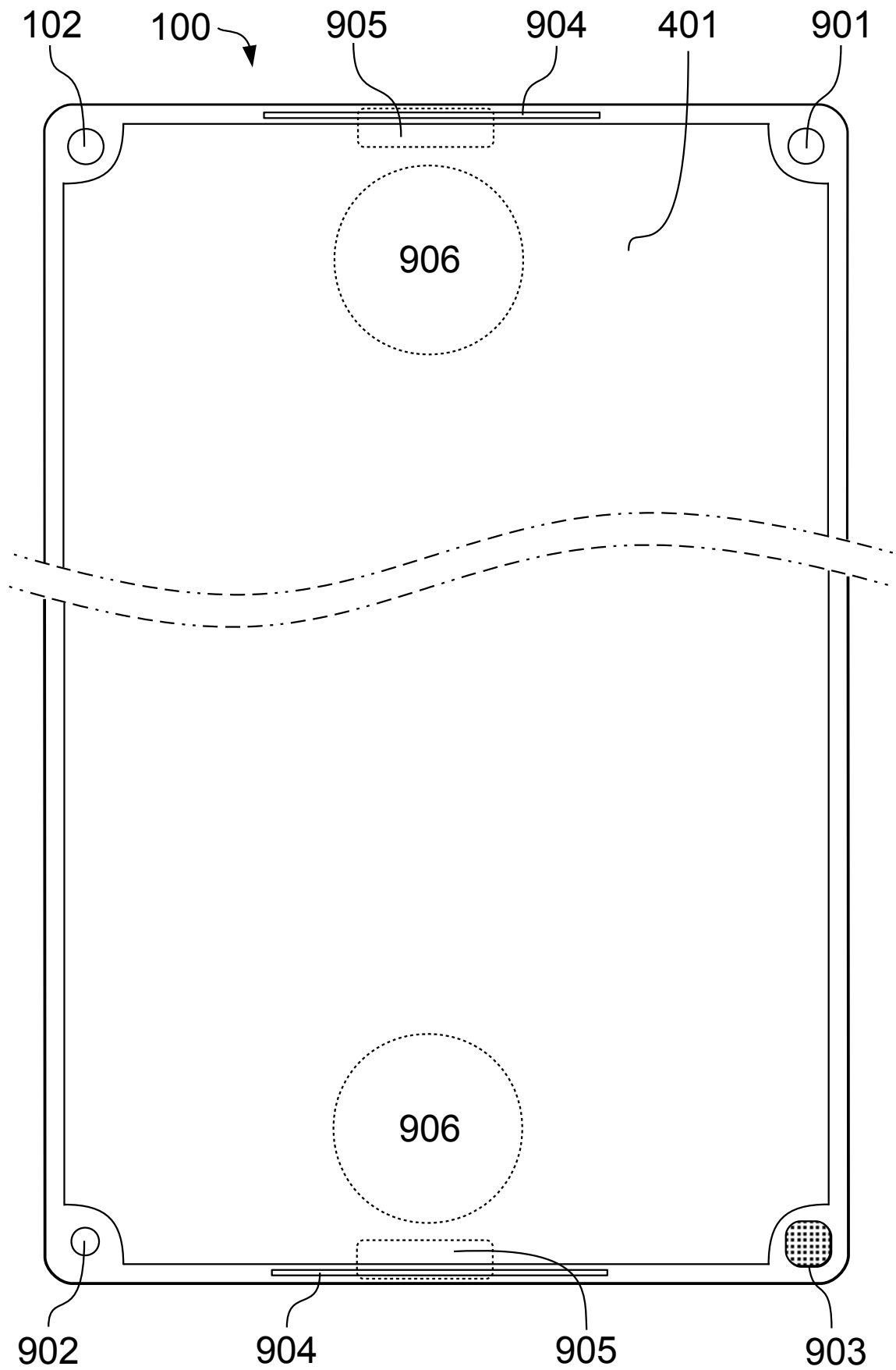

FIG. 9

7/25

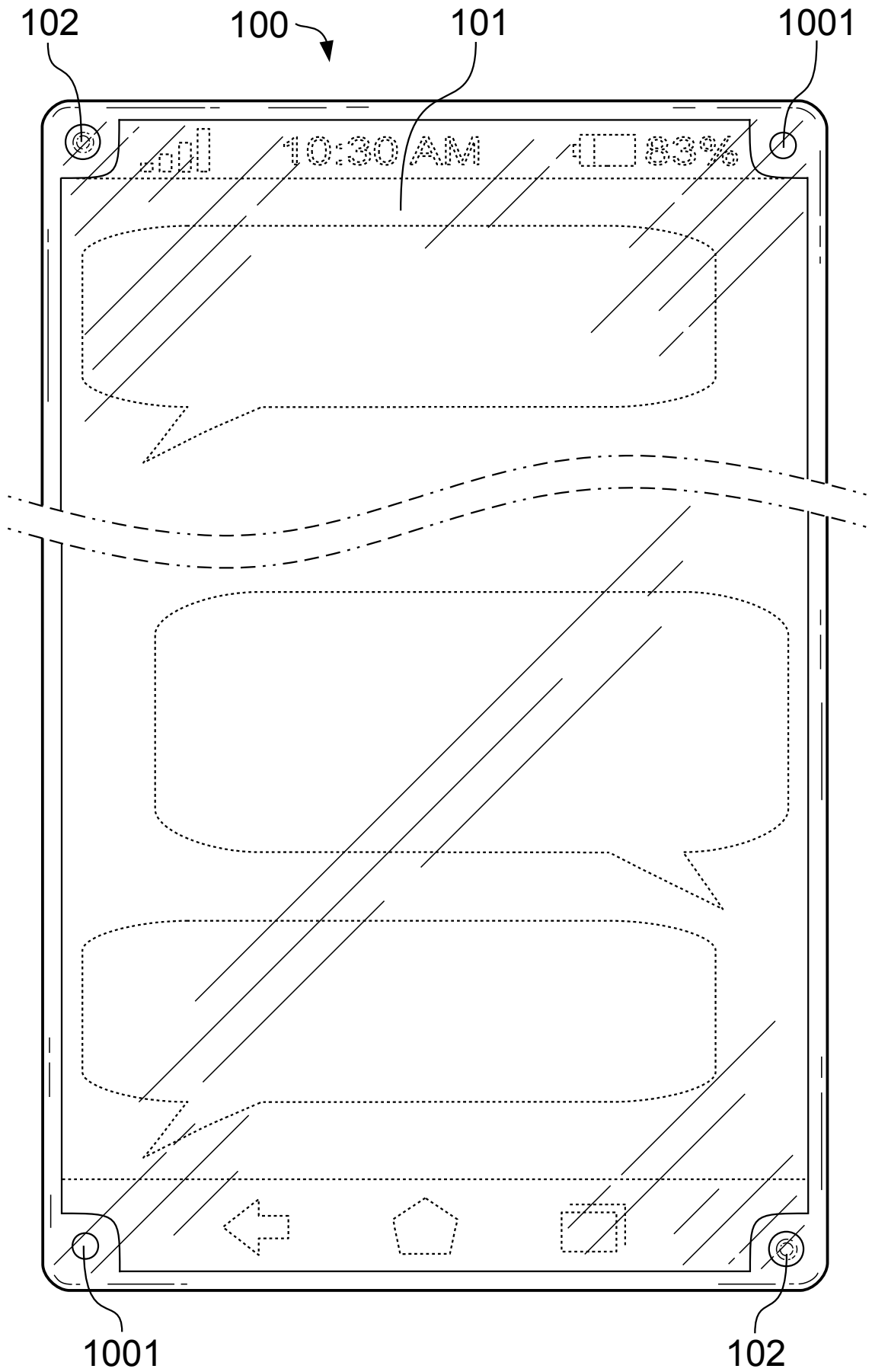
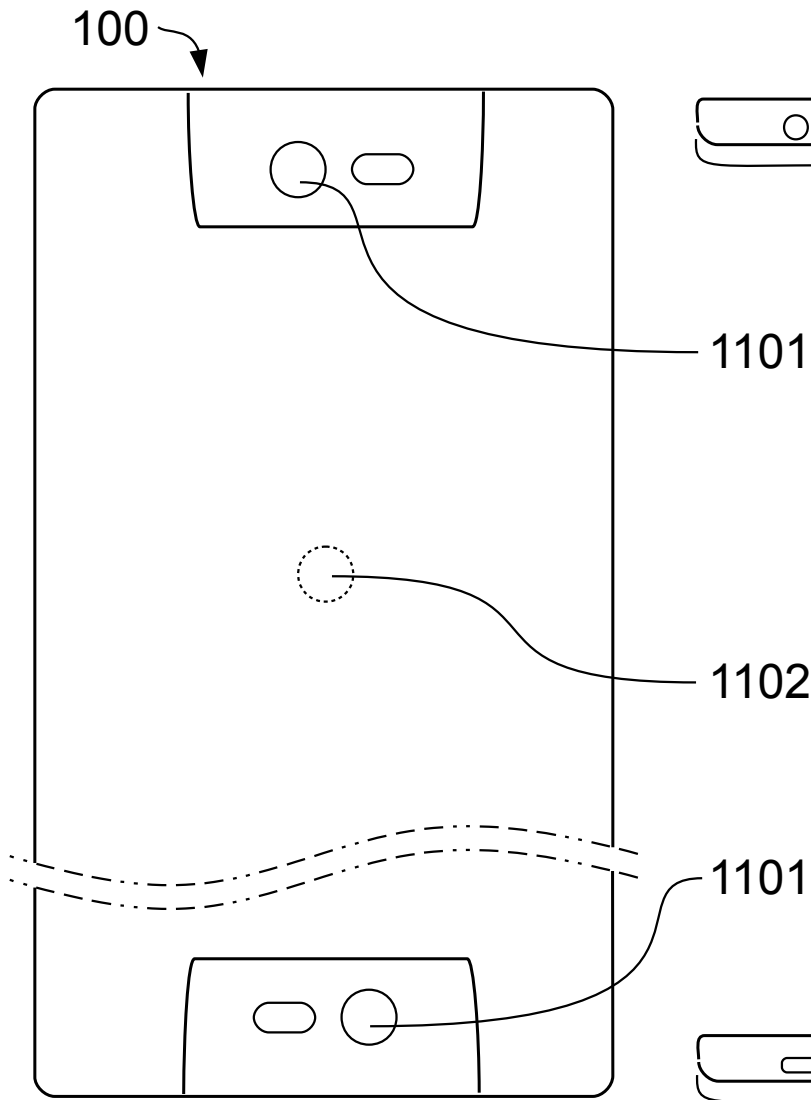
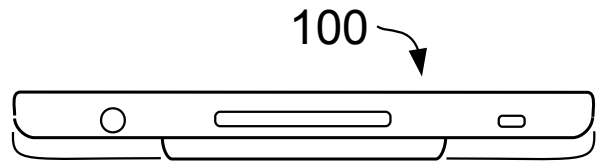

FIG. 10



**FIG. 11**



**FIG. 12**

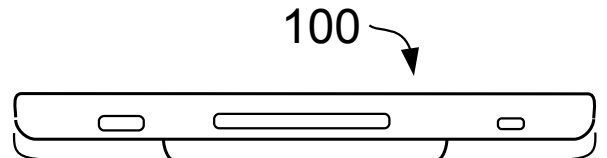

**FIG. 13**

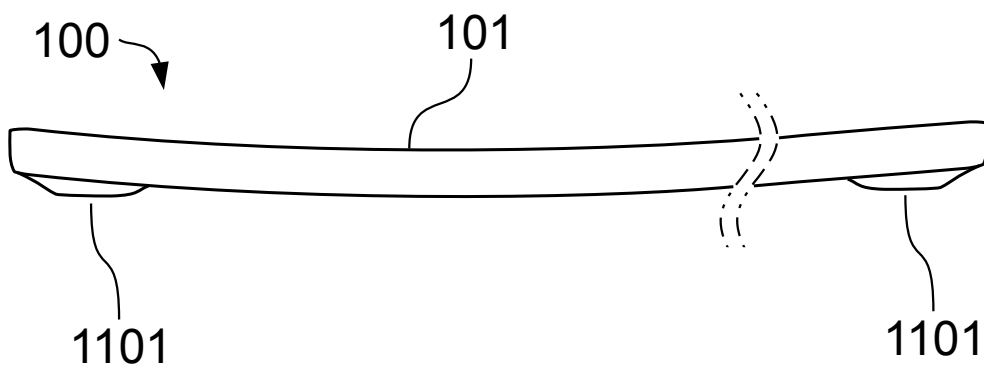

**FIG. 14**



9/25

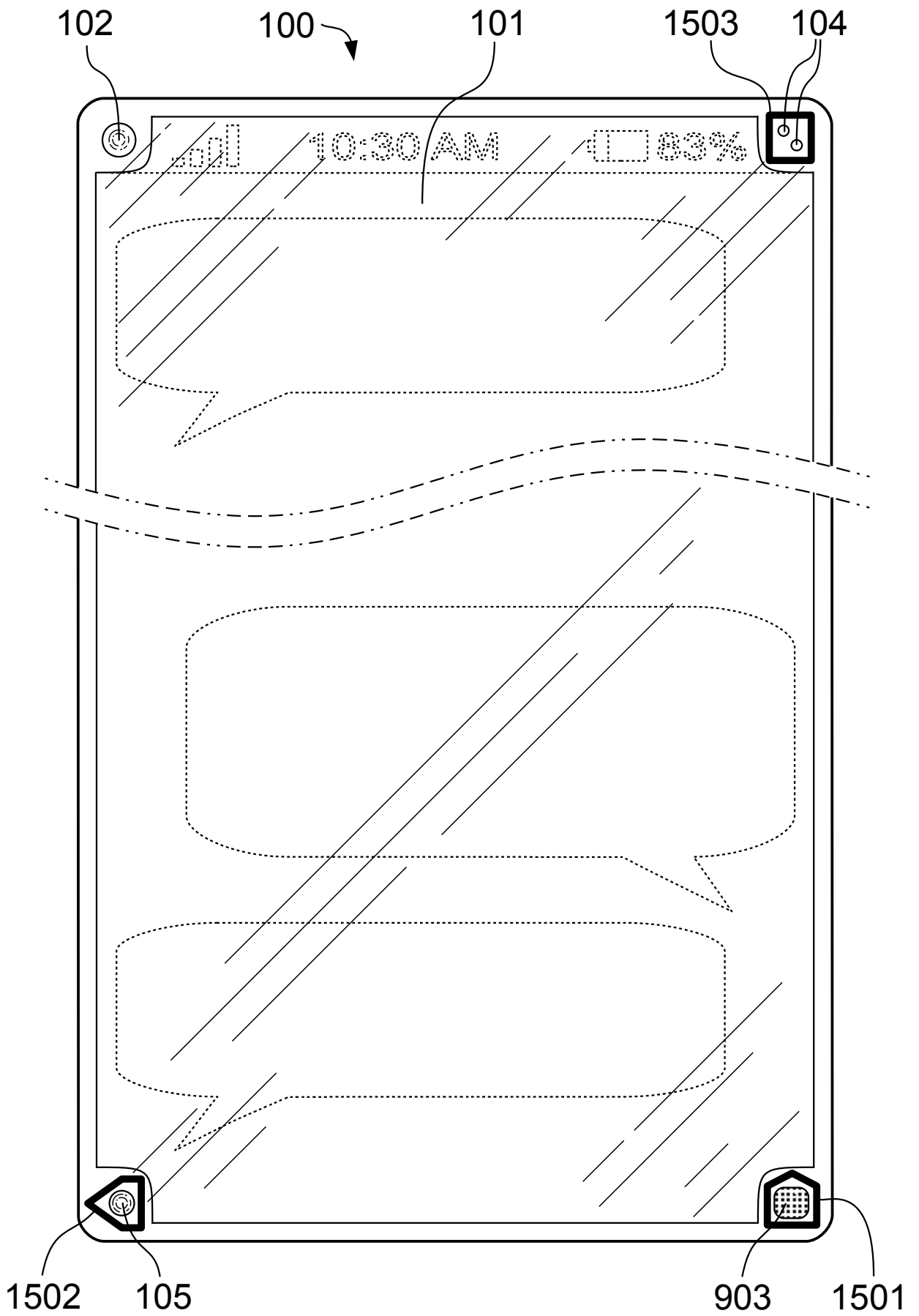

FIG. 15

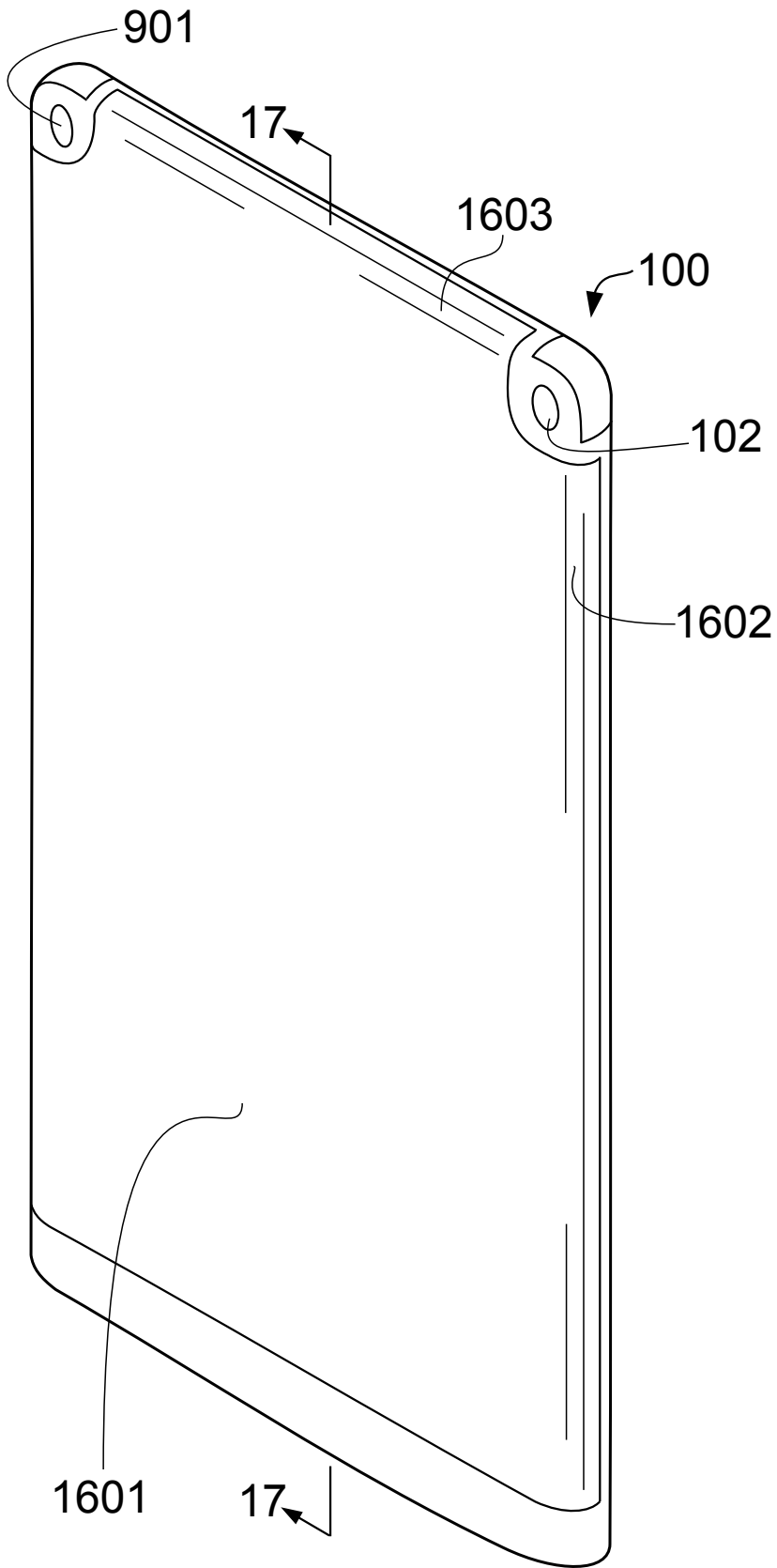

FIG. 16

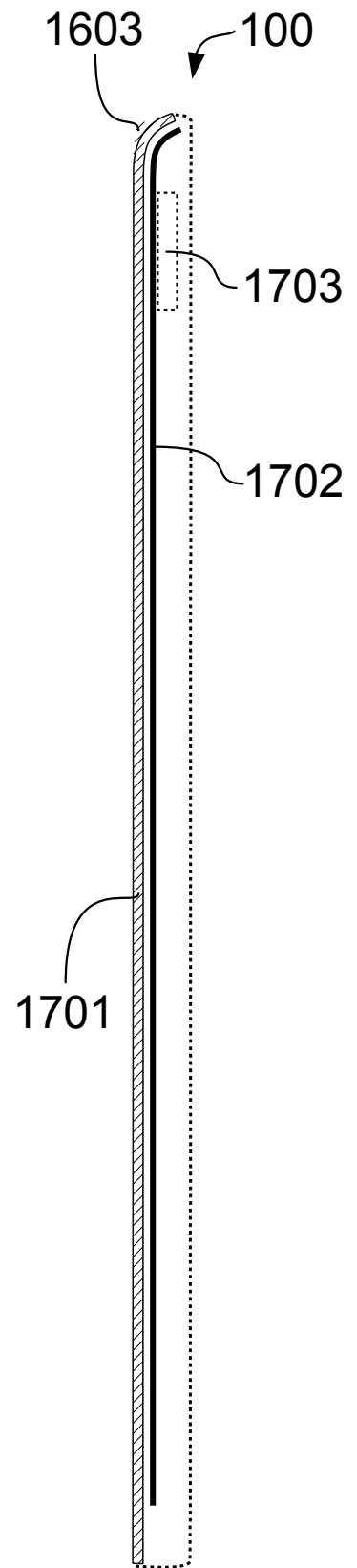

FIG. 17

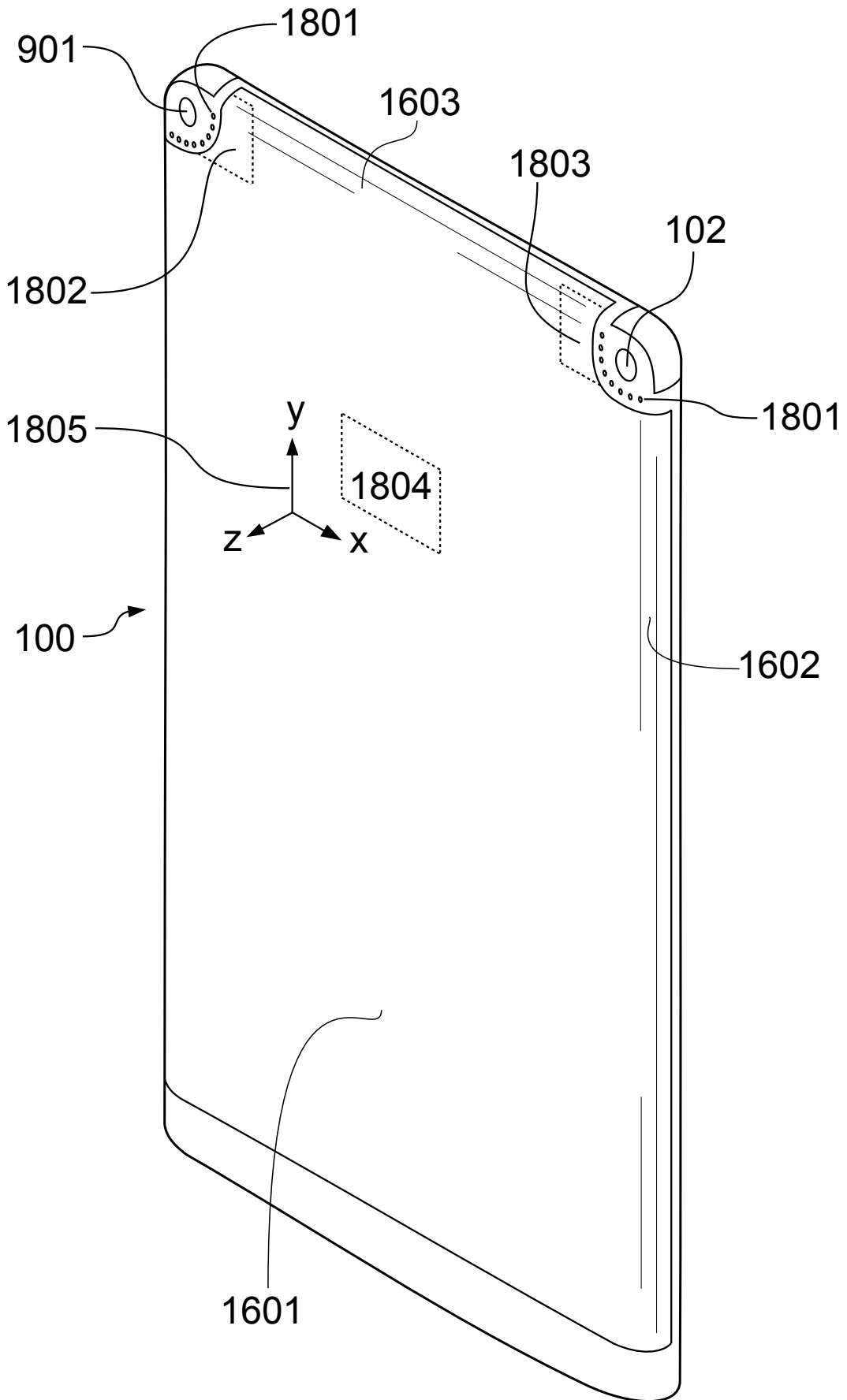

FIG. 18

12/25

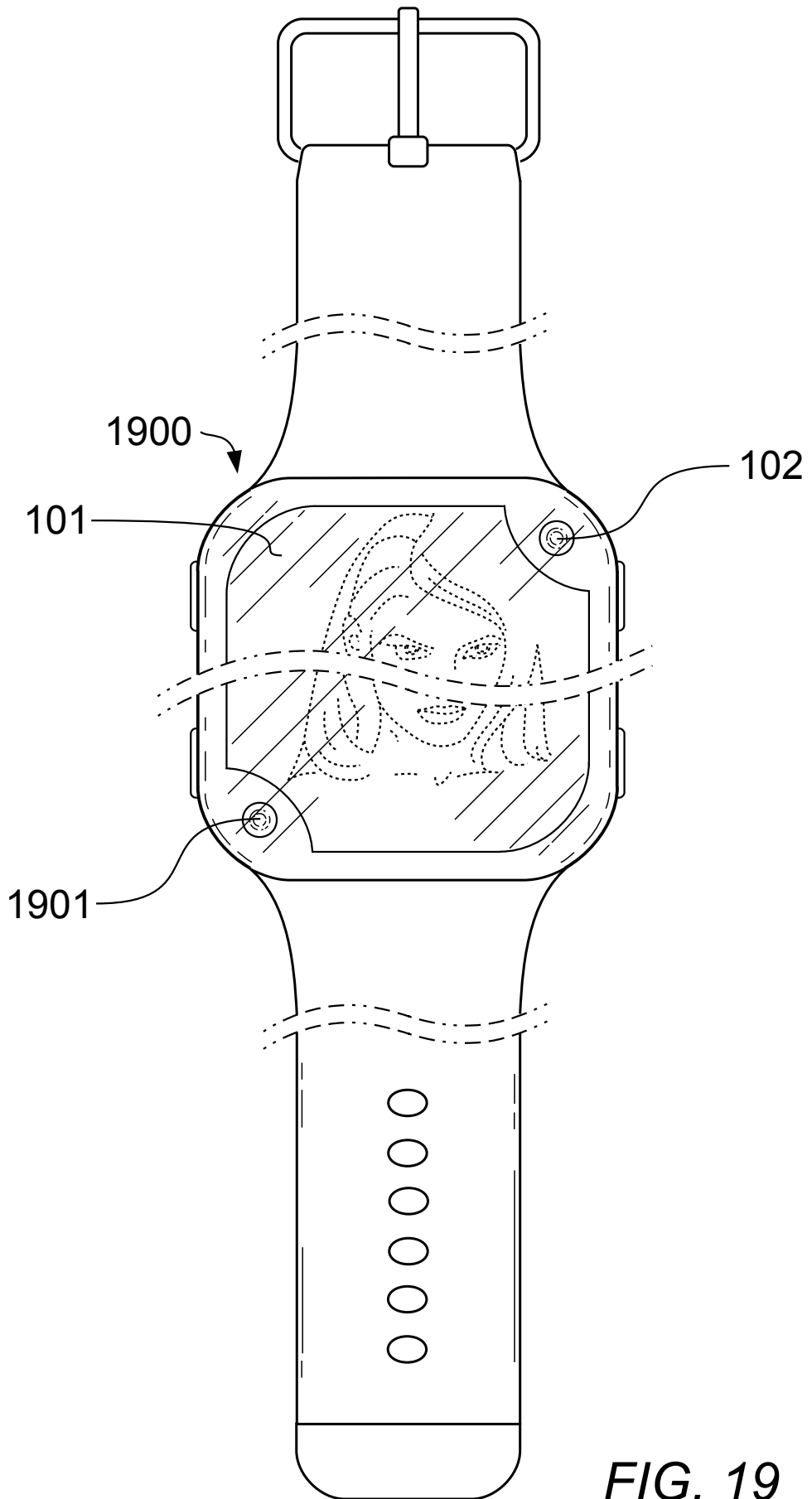

FIG. 19

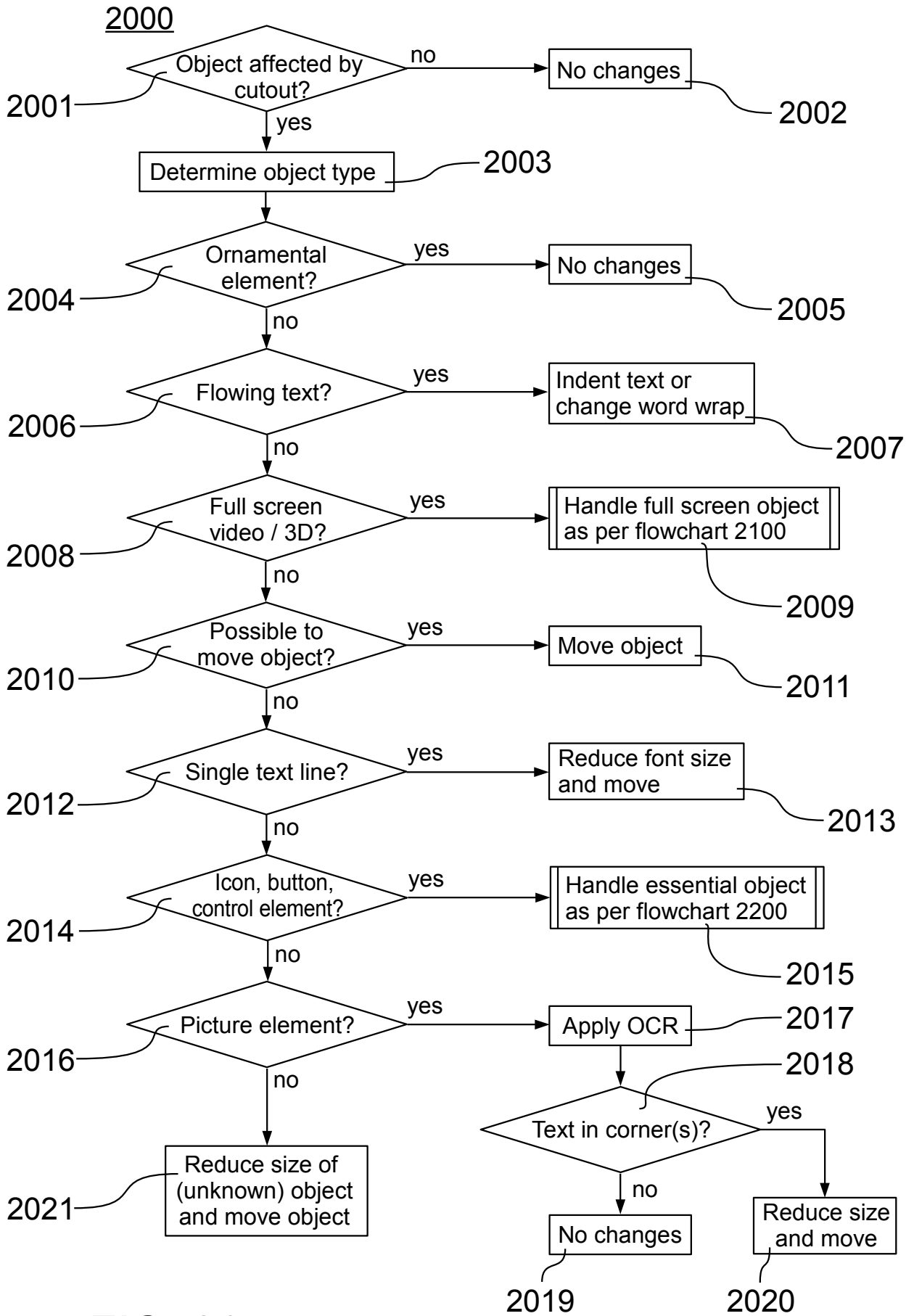

FIG. 20

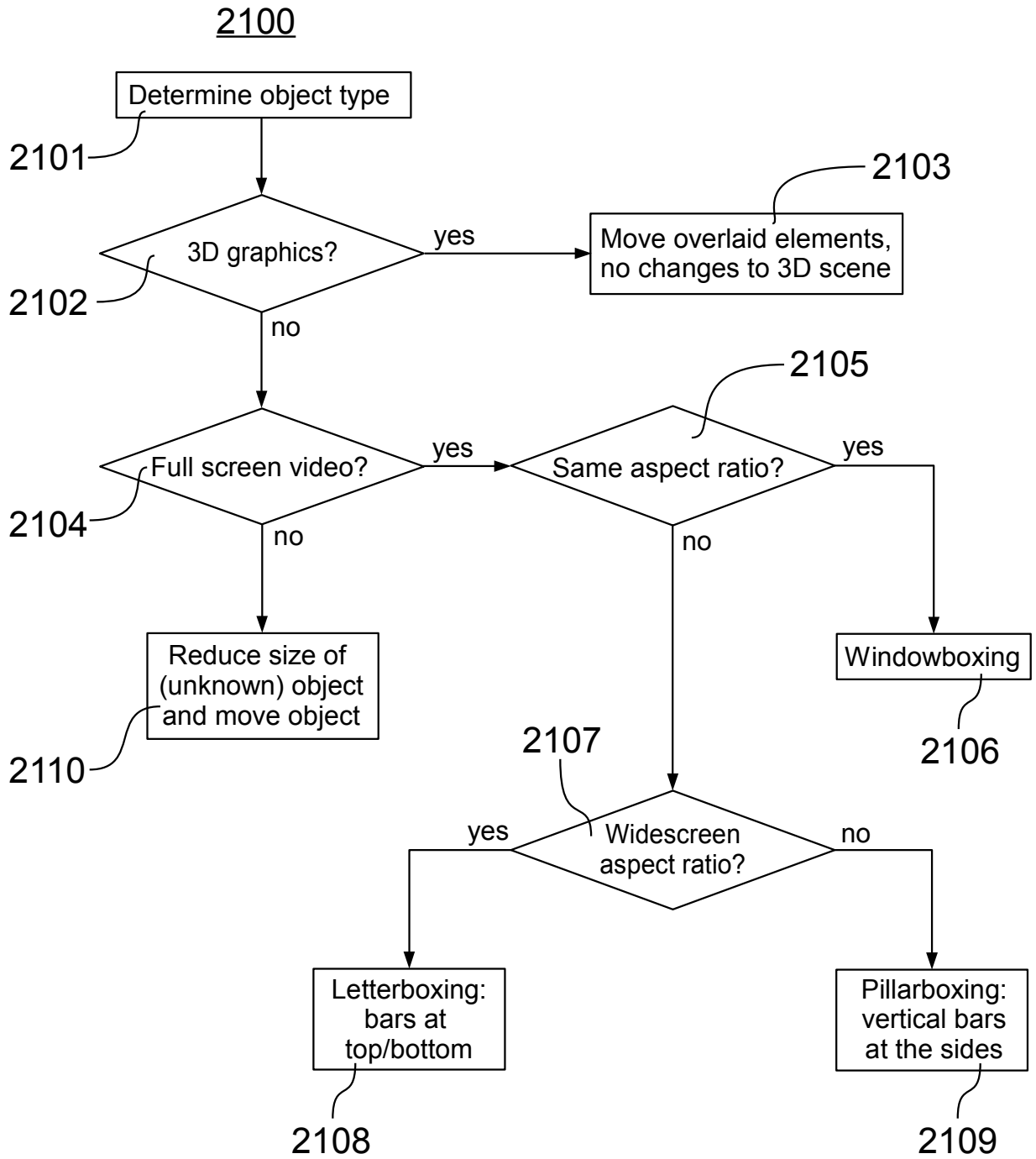

FIG. 21

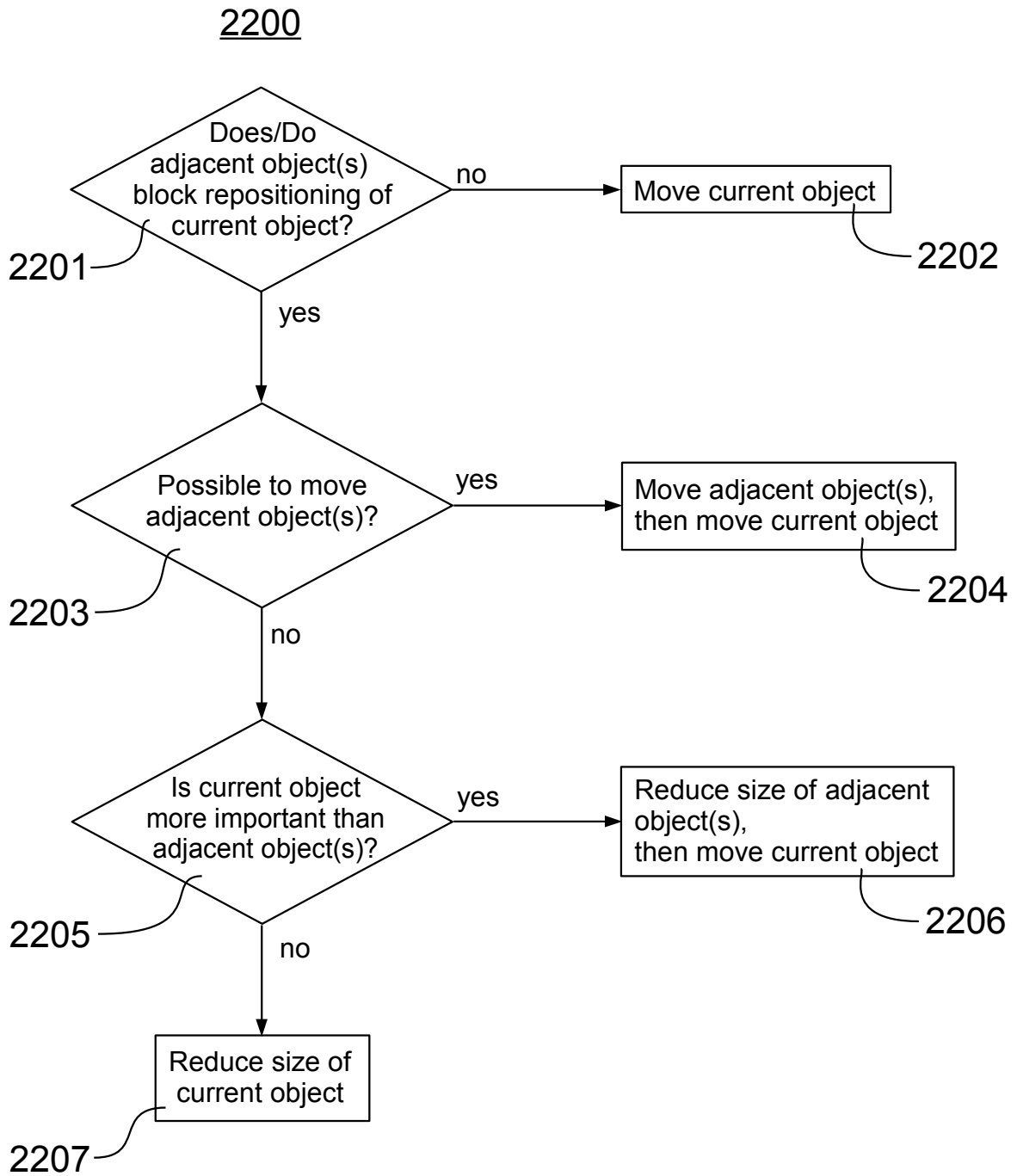

FIG. 22

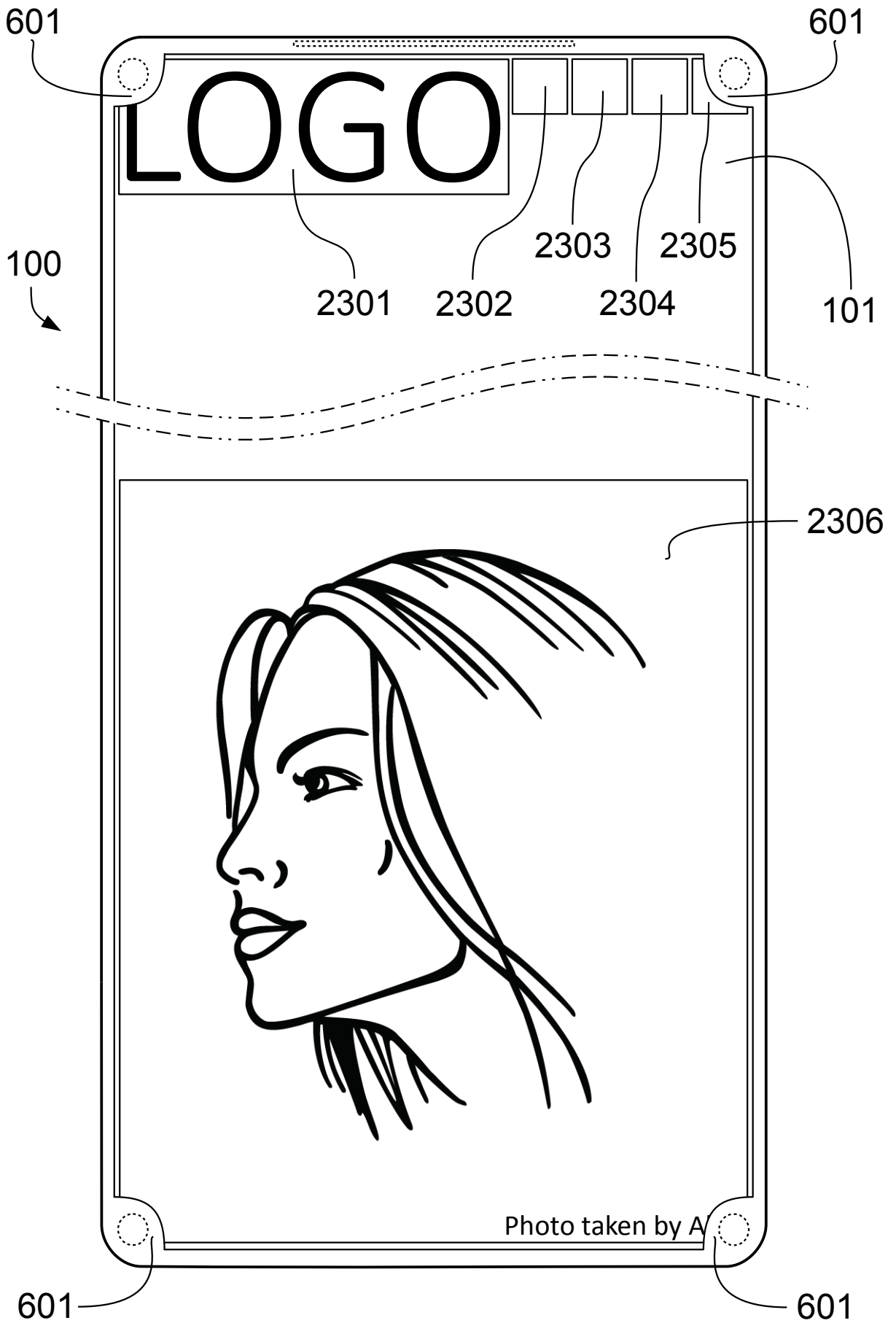

FIG. 23



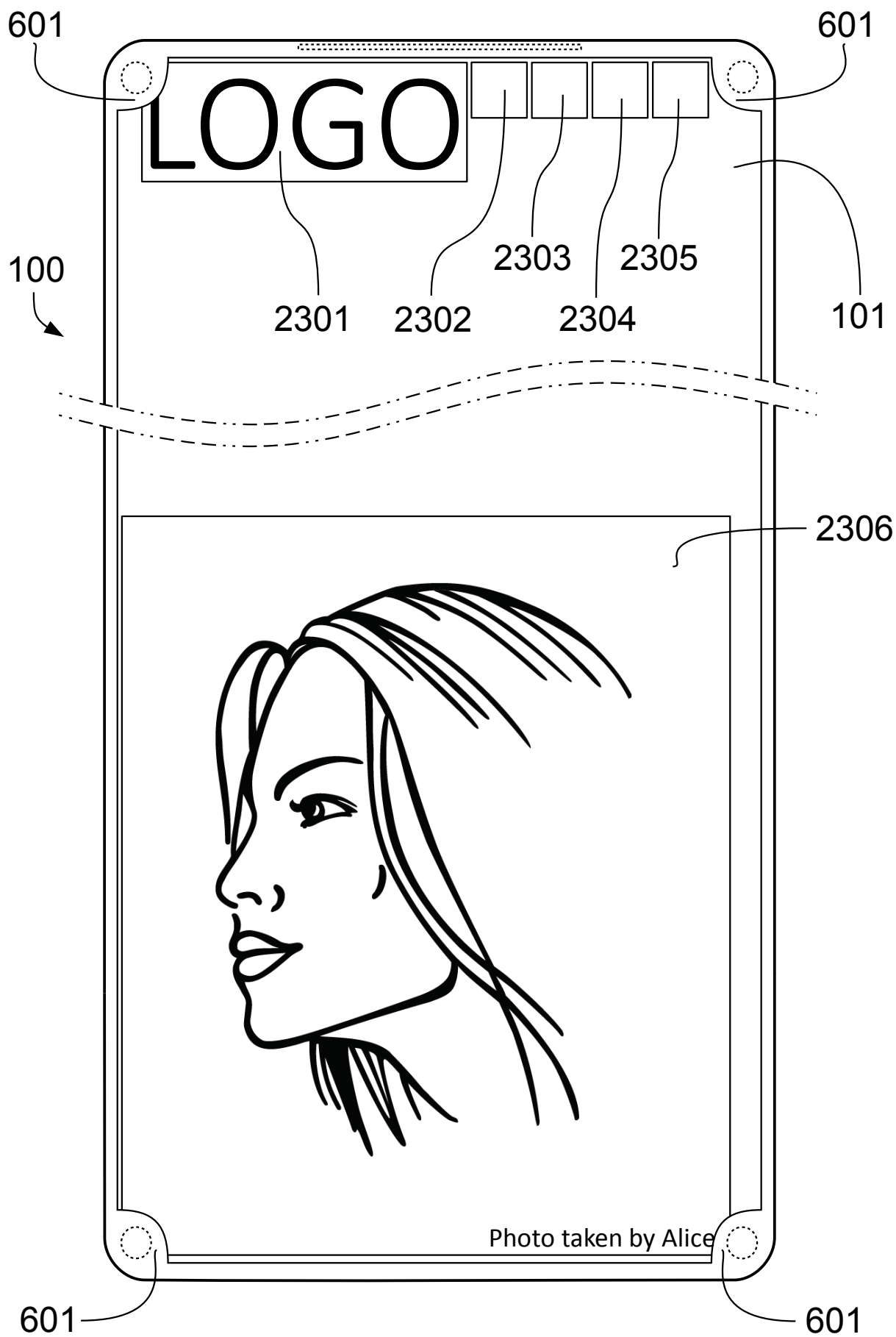

FIG. 24

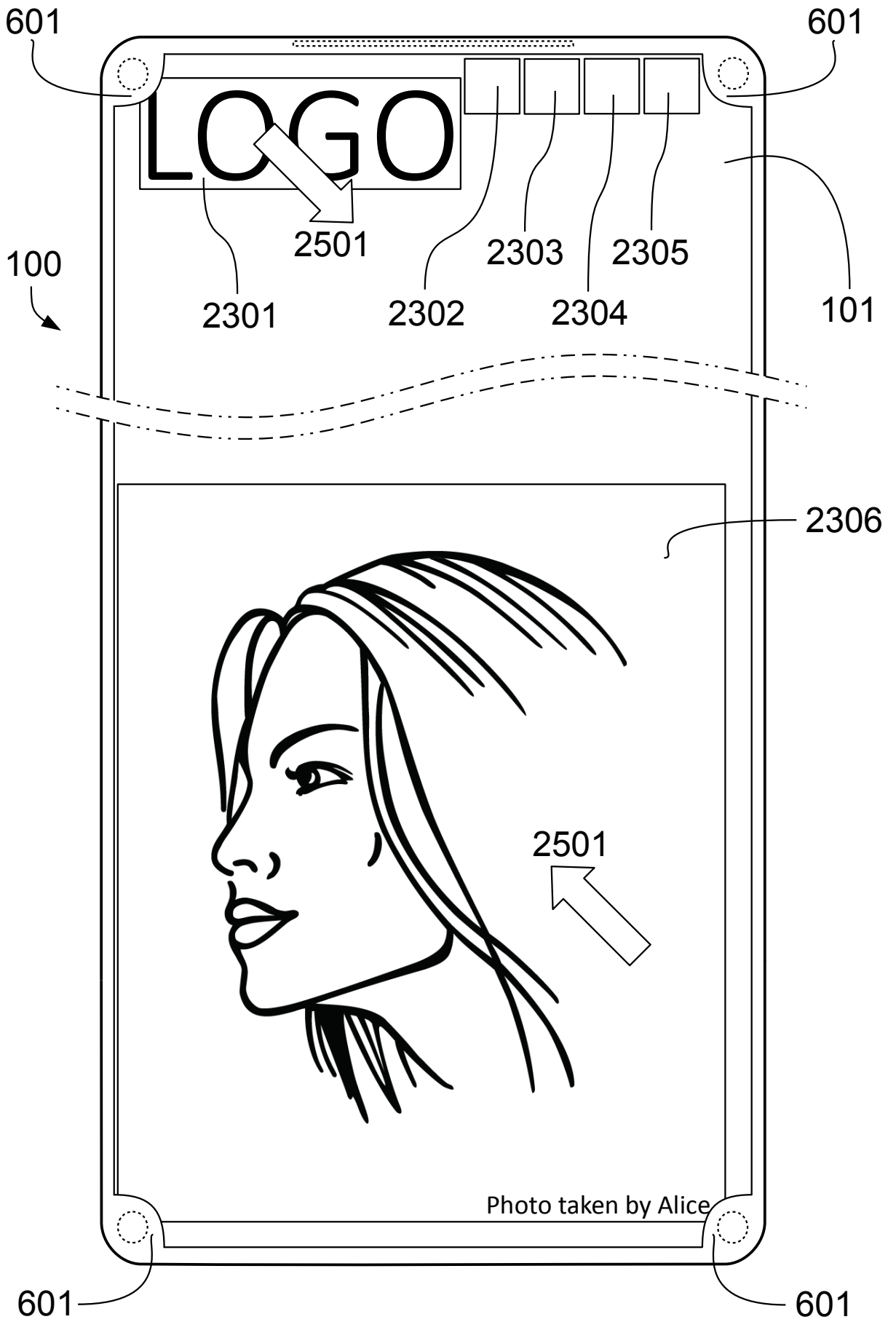

FIG. 25

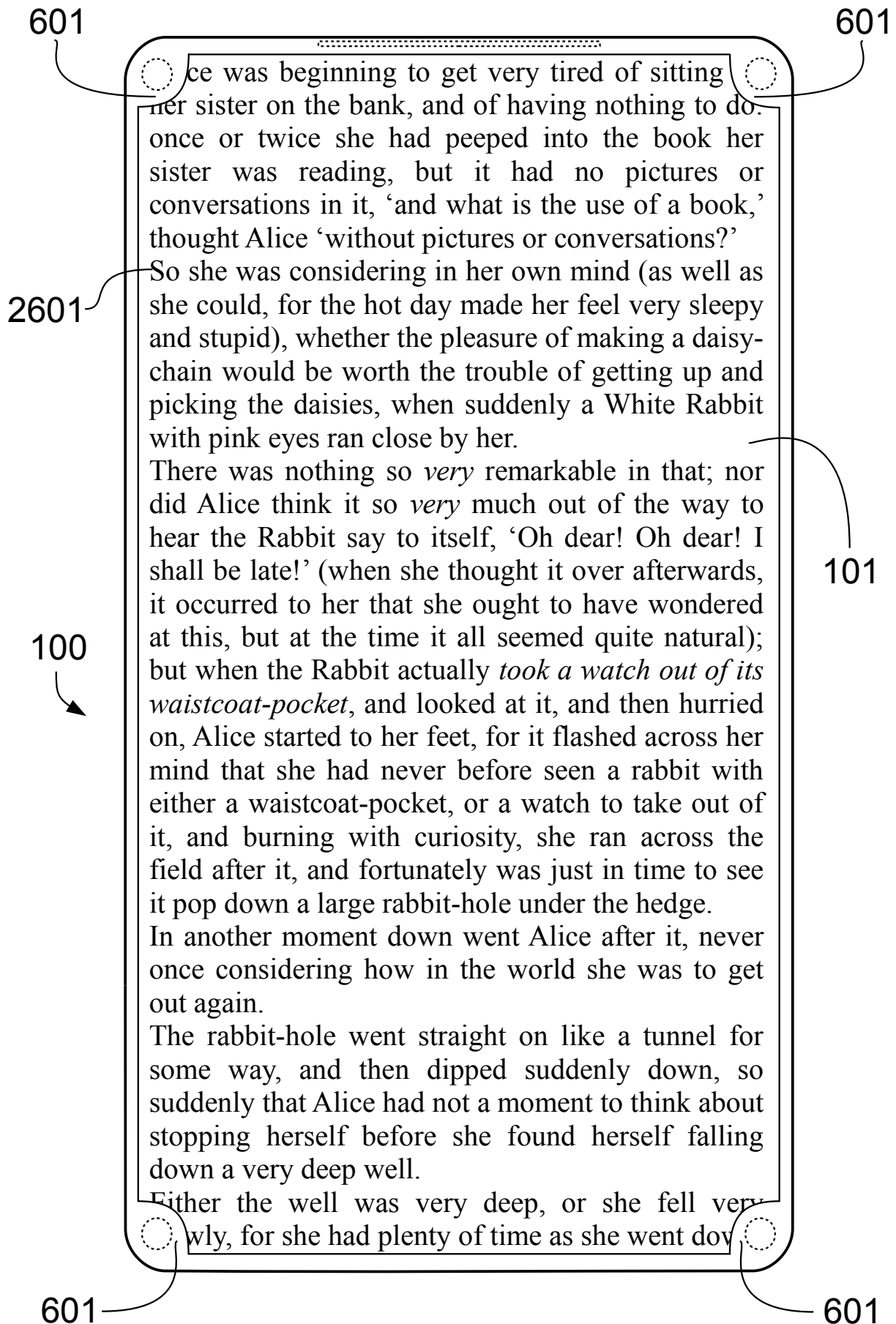

FIG. 26

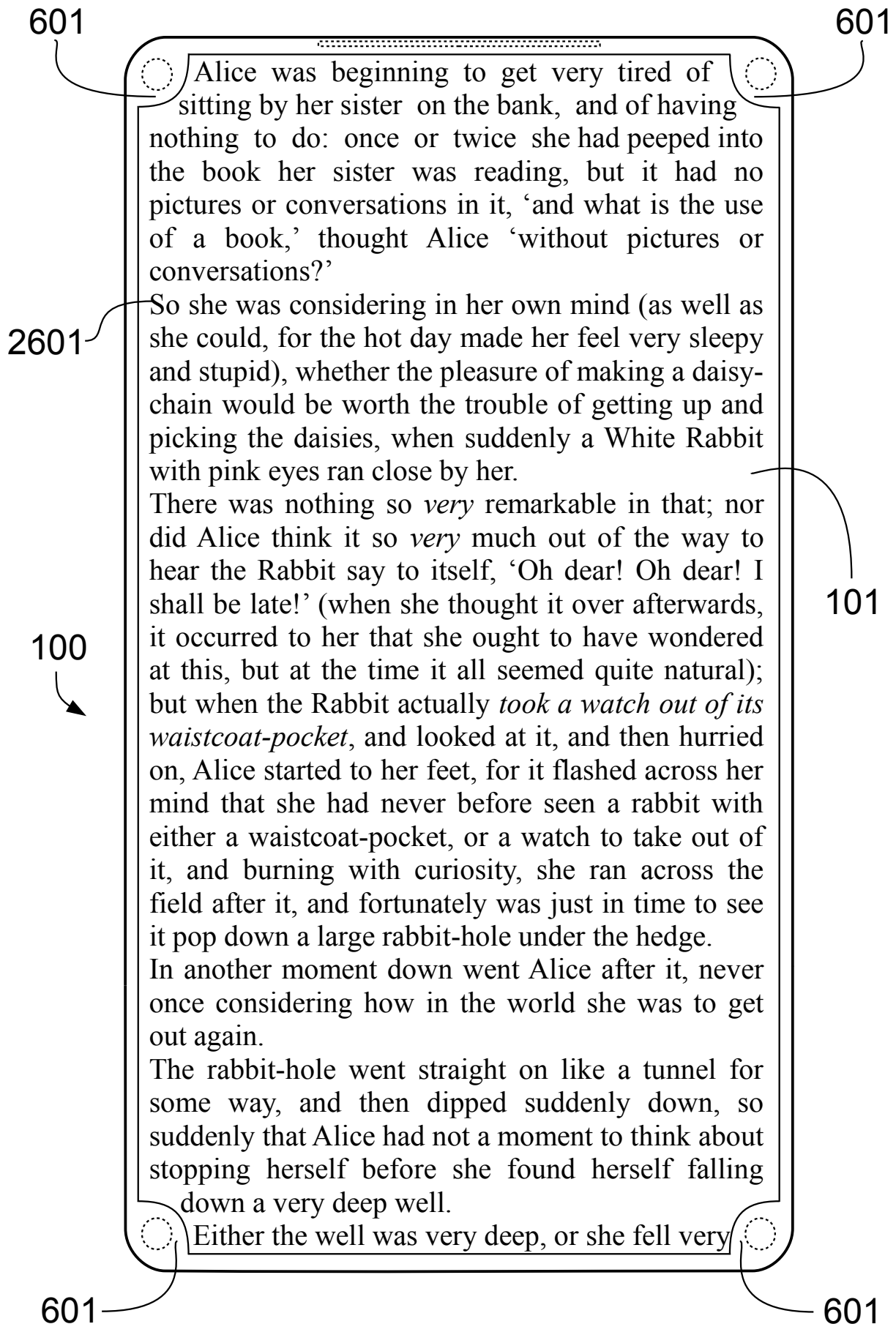

FIG. 27

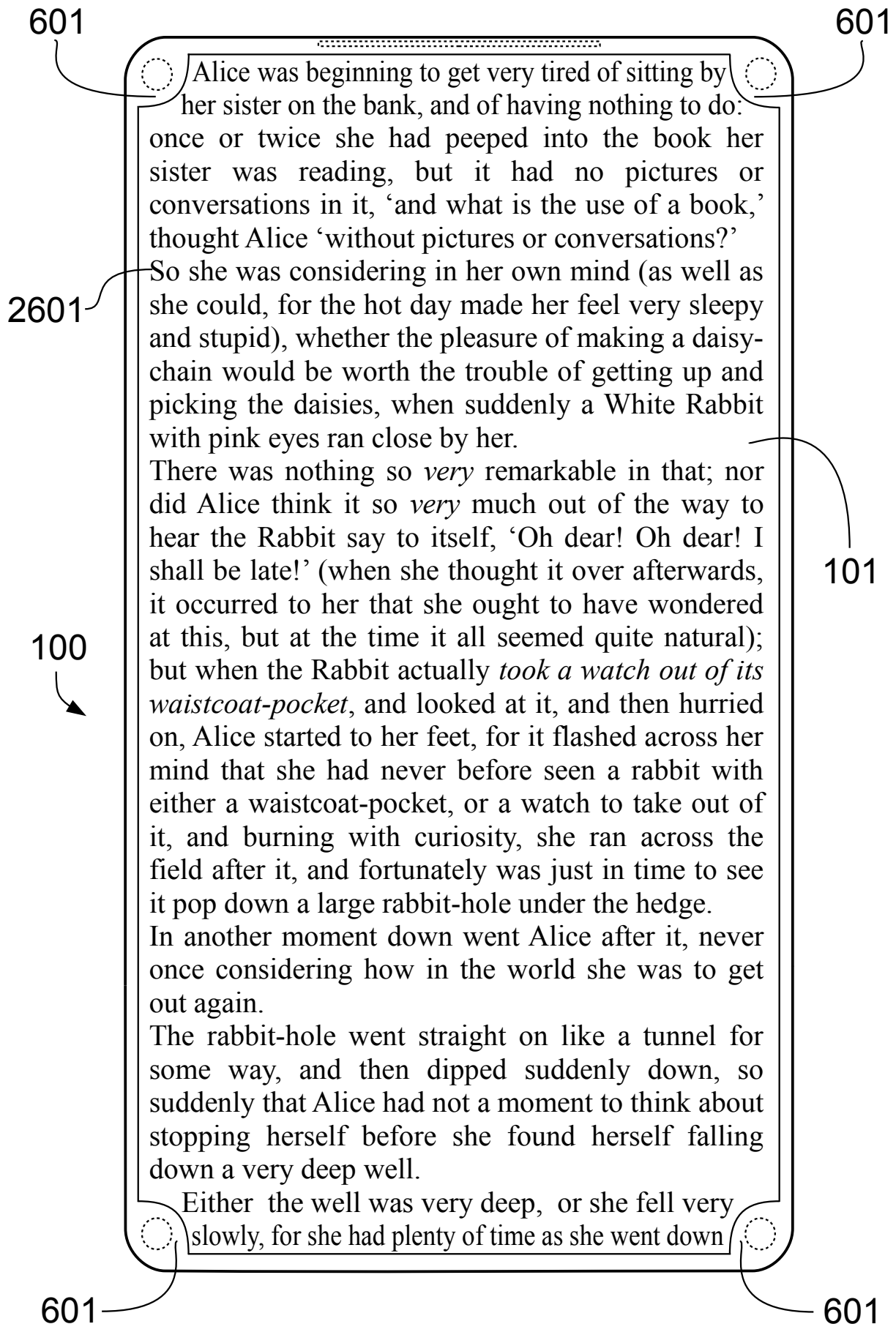

FIG. 28

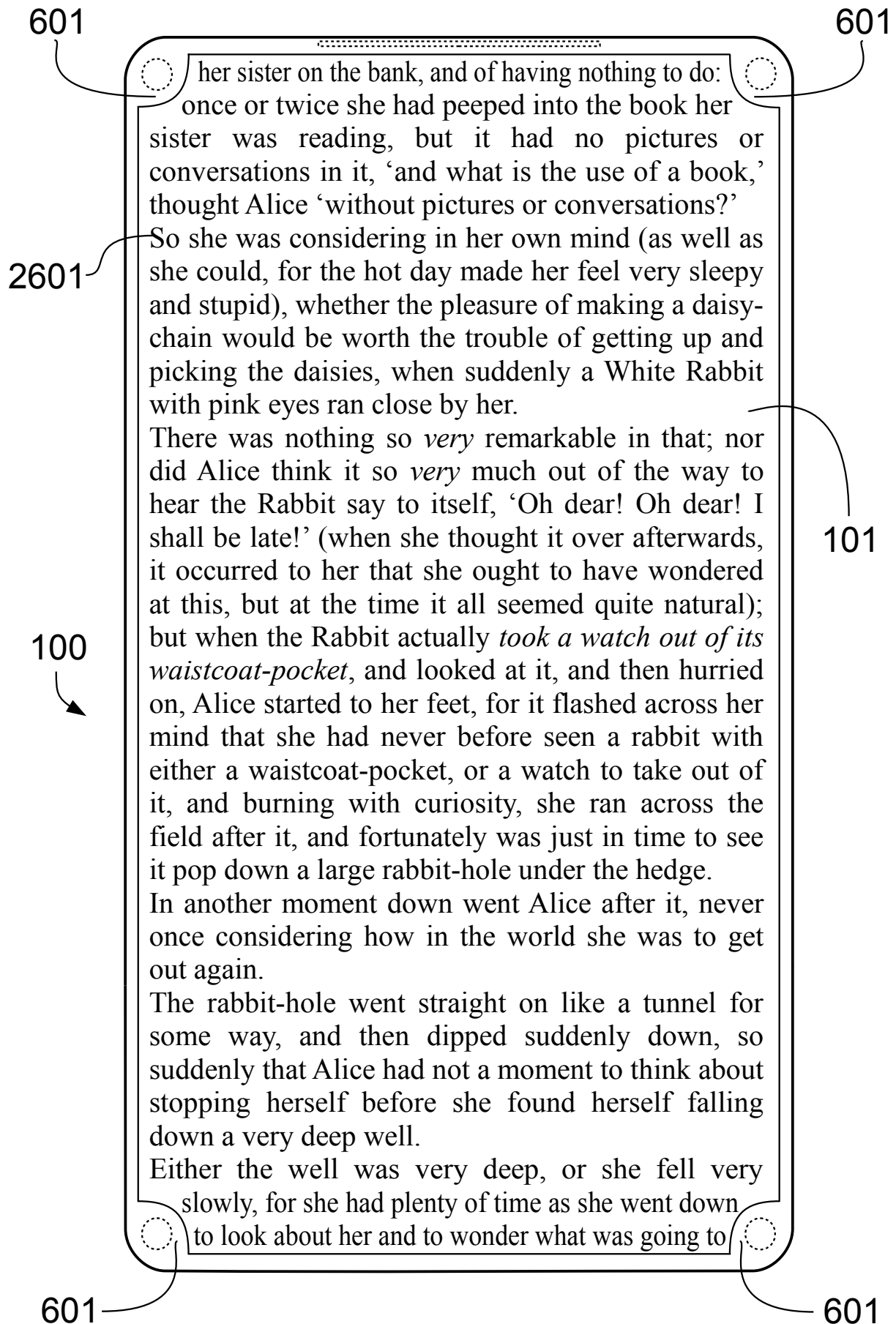

FIG. 29

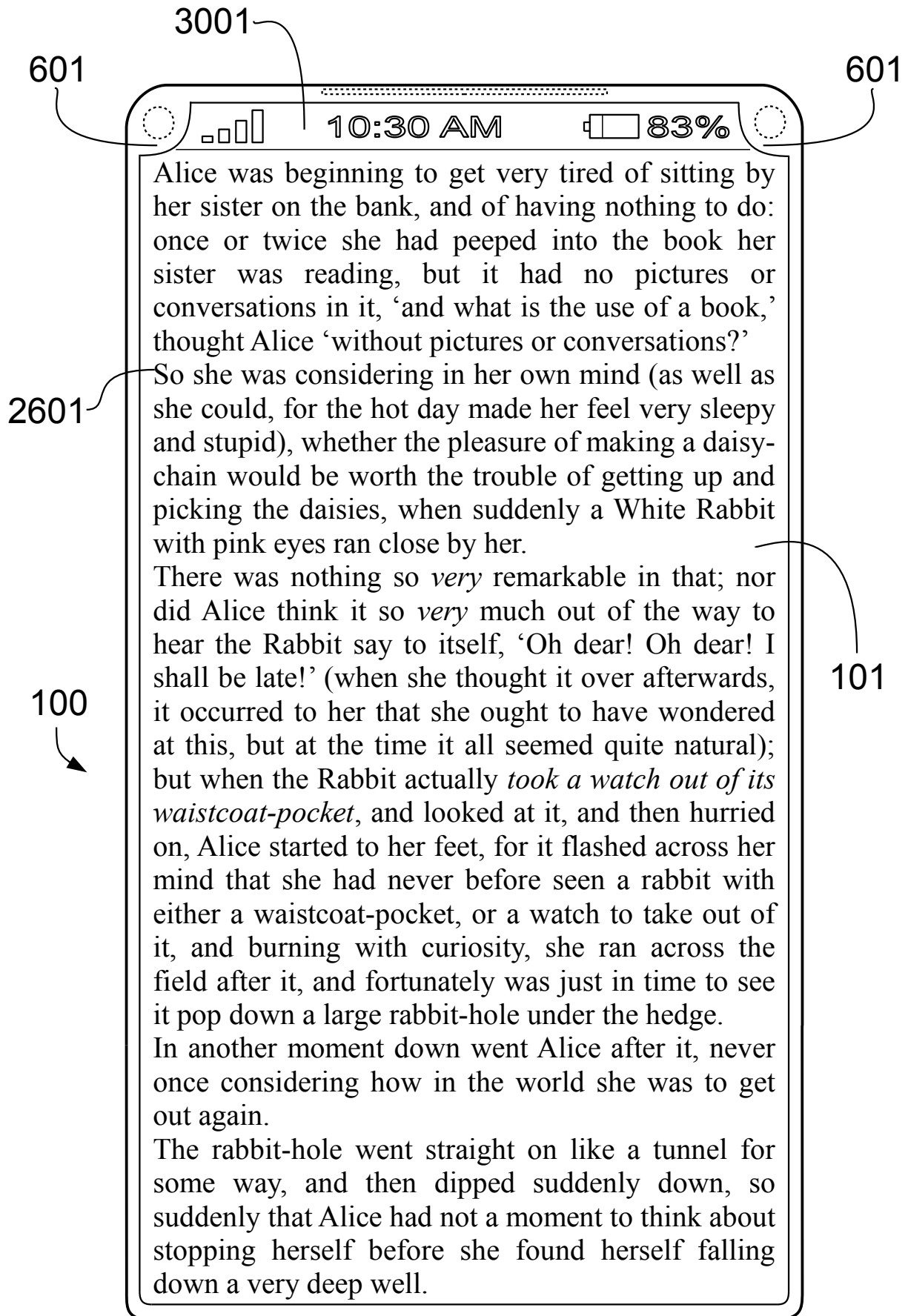

FIG. 30

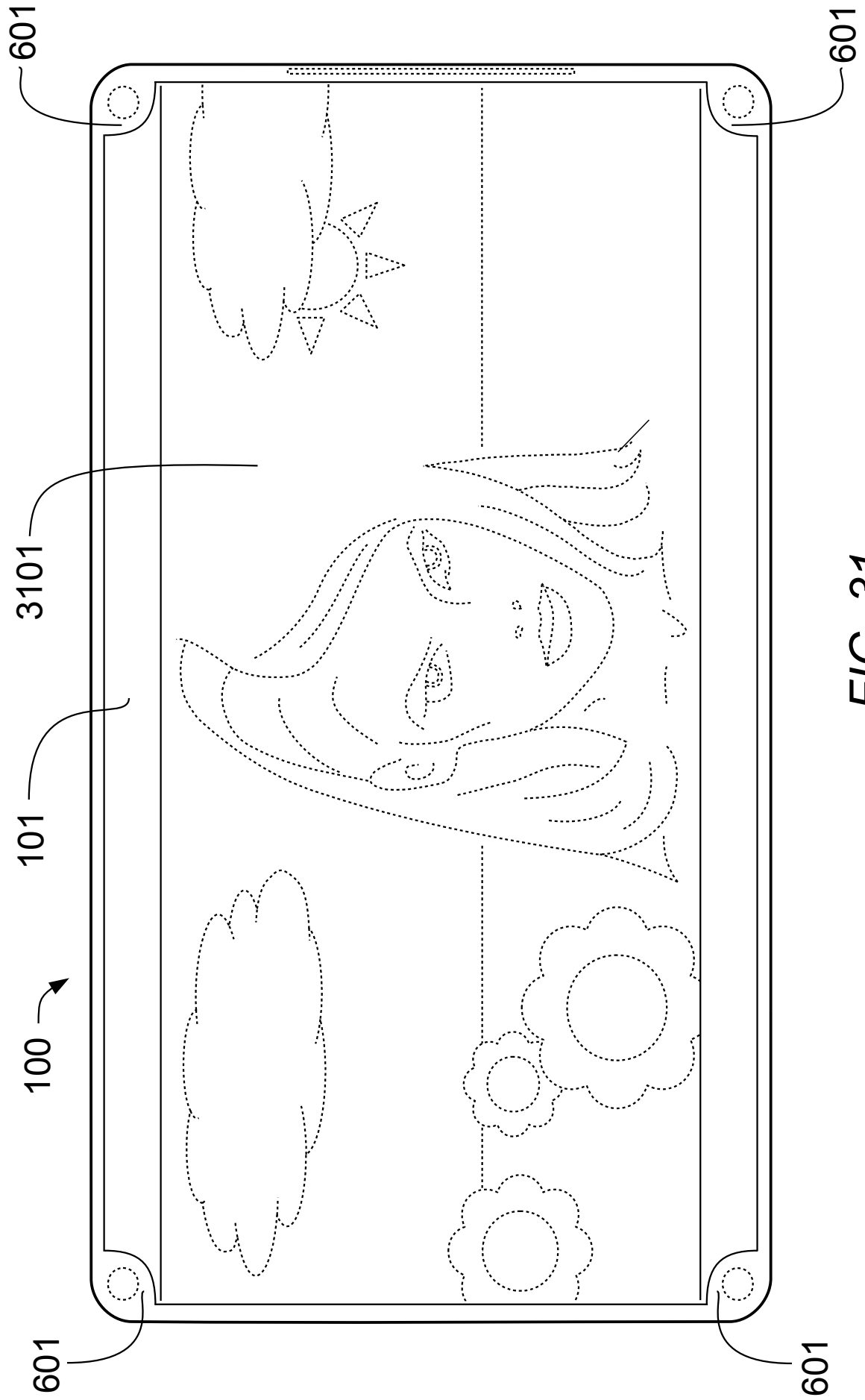

FIG. 31



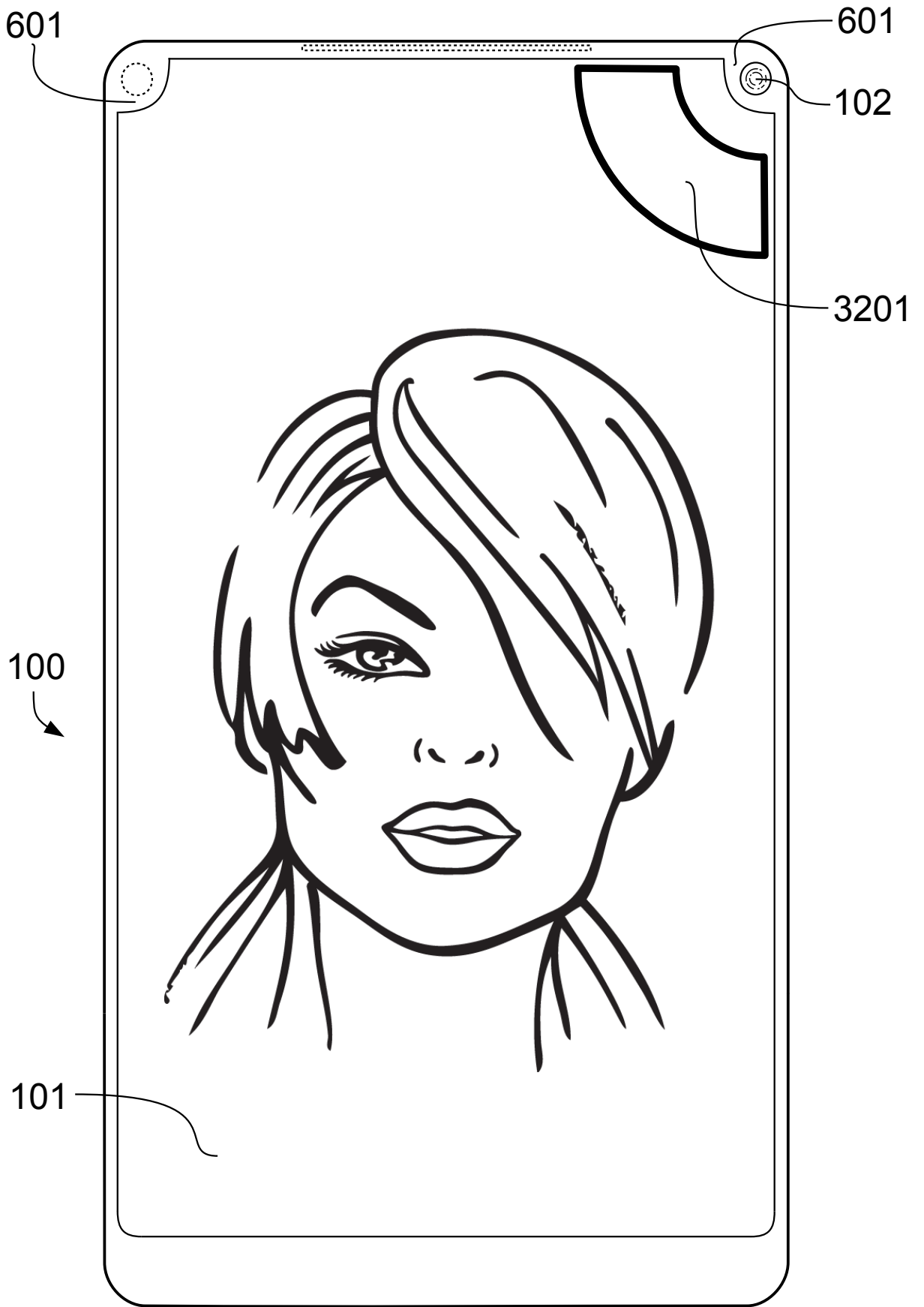

FIG. 32